

鑽石斷屑刀片

---

PCD  
Chip-Break Tool

# 鑽石斷屑刀片 PCD Chip-Break Tool

## 鑽石斷屑刀片系列

外徑專用

(本圖示為右手R)

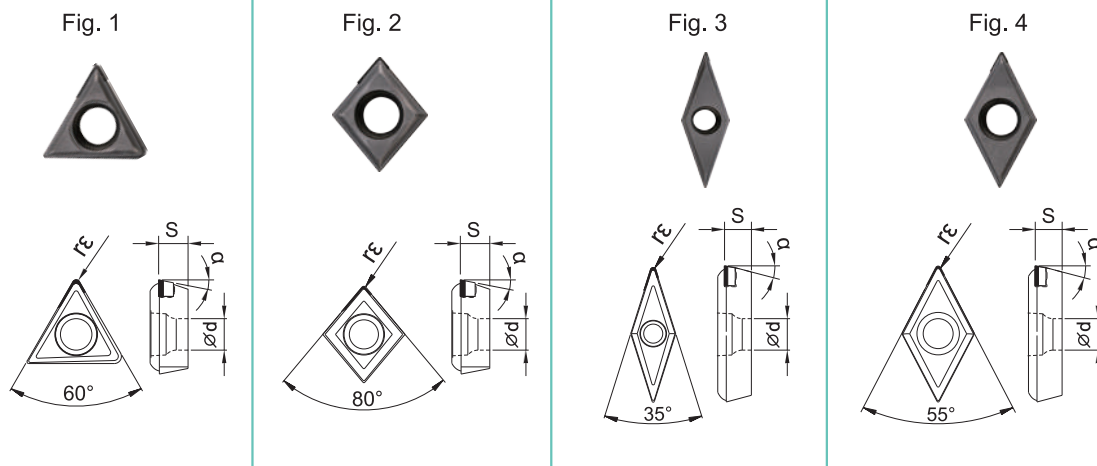

外徑專用	刀具料號 Model No.	尺寸(mm) dimension				形狀 Figure	在庫 R
		S	ød	α	rε		
	DQTPGT110302 R/L	3.18	3.3	11°	0.2	Fig. 1	●
	DQTPGT110304 R/L				0.4	Fig. 1	●
	DQTPGT110308 R/L				0.8	Fig. 1	●
	DQCCGT060202 R/L	2.38	2.8	7°	0.2	Fig. 2	●
	DQCCGT060204 R/L				0.4	Fig. 2	●
	DQCCGT09T302 R/L				0.2	Fig. 2	●
	DQCCGT09T304 R/L	3.97	4.4	7°	0.4	Fig. 2	●
	DQVCGT110302 R/L	3.18	2.8	7°	0.2	Fig. 3	●
	DQVCGT110304 R/L				0.4	Fig. 3	●
	DQVCGT160402 R/L				0.2	Fig. 3	●
	DQVCGT160404 R/L	4.76	4.4	7°	0.4	Fig. 3	●
	DQVCGT160408 R/L				0.8	Fig. 3	●
	DQVCGT160412 R/L				1.2	Fig. 3	●
	DQDCGT070202 R/L	2.38	2.8	7°	0.2	Fig. 4	●
	DQDCGT070204 R/L				0.4	Fig. 4	●
	DQDCGT11T302 R/L				0.2	Fig. 4	●
	DQDCGT11T304 R/L	3.97	4.4	7°	0.4	Fig. 4	●

○: 接單生產品    ●: 在庫品    ▲: 訂製品